

MCC Controller

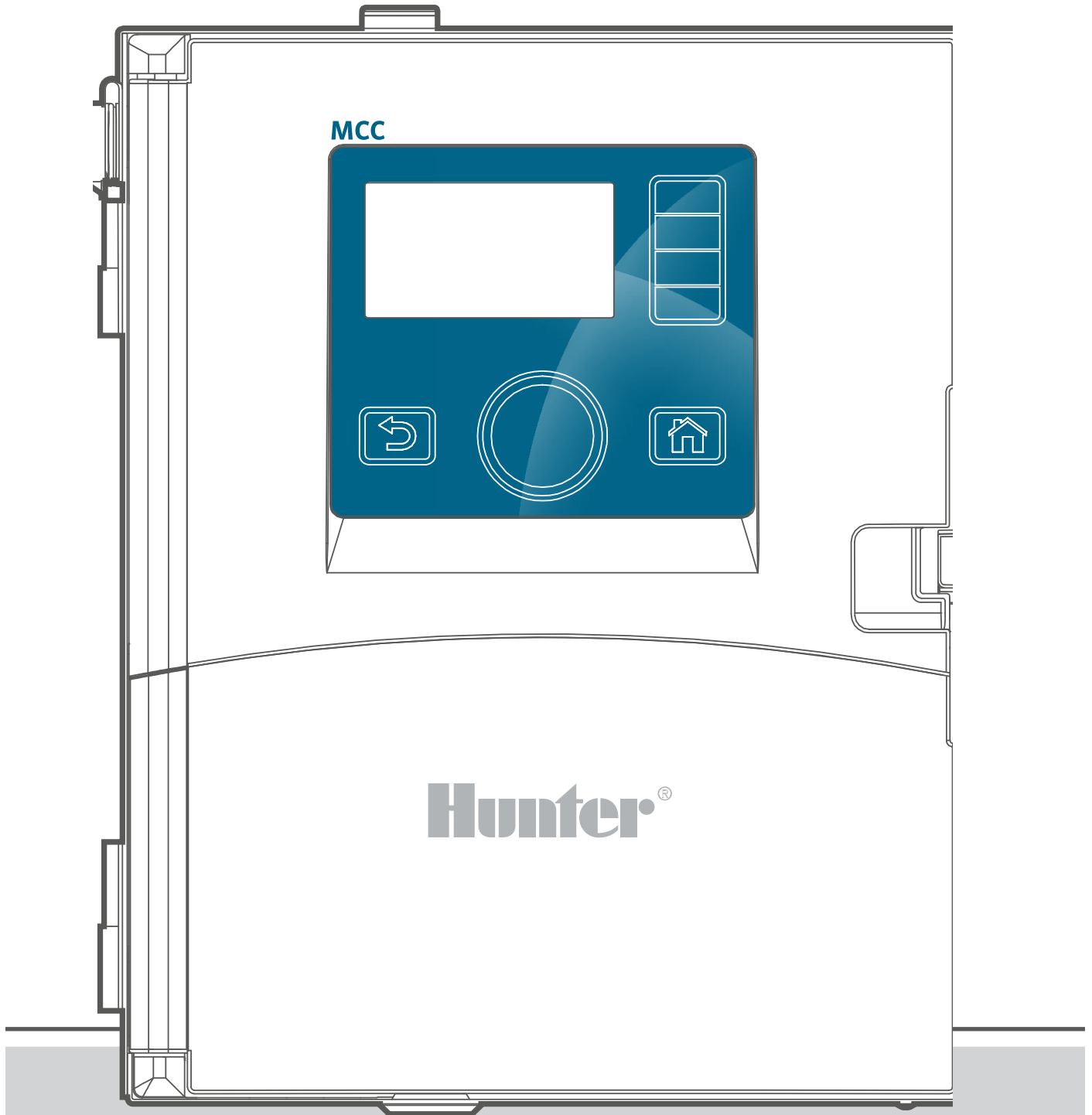

MCC Controller

The value leader in commercial irrigation control, offering advanced water-saving features at a moderate price point.

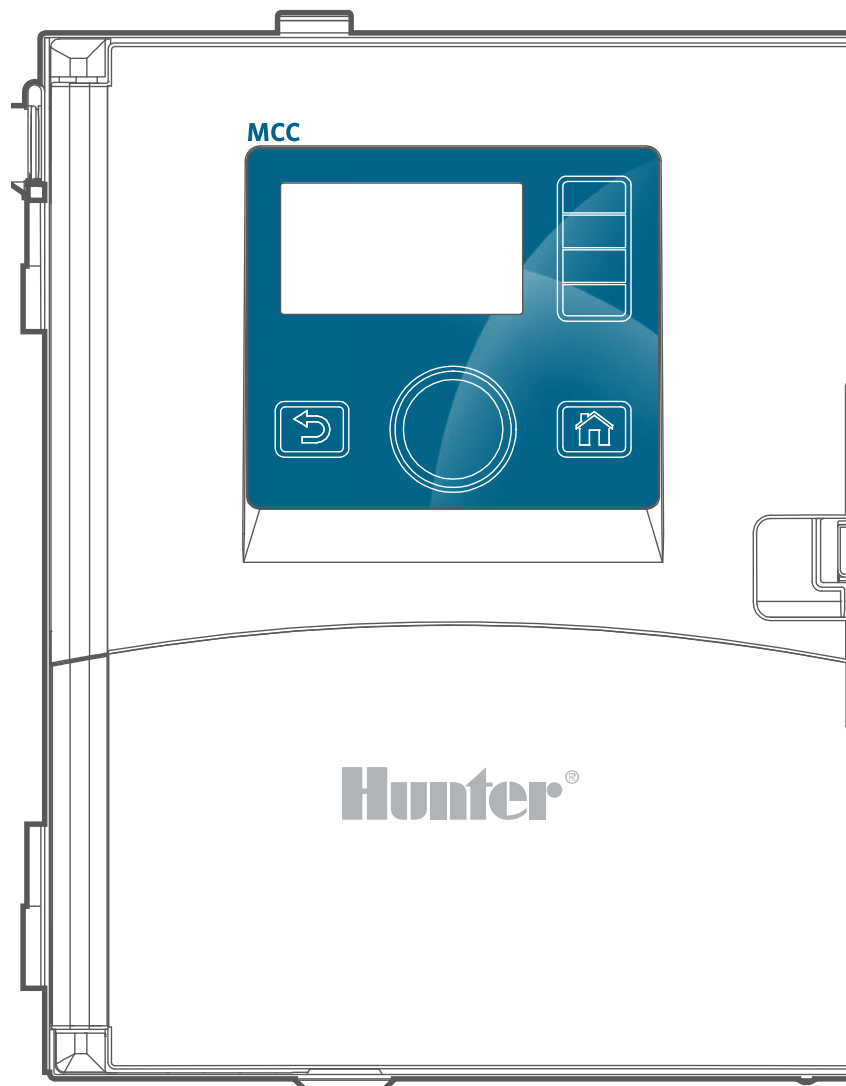

Troubleshooting

Need more helpful information on your product? Find tips on installation, controller programming, and more.



hunter.help/MCCem

TABLE OF CONTENTS

Module Compatibility	4	Stations Menu	16	Flow Operations	27
Station Expansion	4	Station Setup	16	Flow Manager	27
Key Connections	4	Cycle & Soak	16	Flow Monitor	28
Controller Components	5	Blocks	16	MainSafe® System Protection	28
Facepack	5	Station Limits	17	MainSafe Setup Screen	28
Wall Mount Bracket	6	Station Summary	17	Flow Limits Screen	28
Wall Mounting	6	Devices Menu	18	Maximum Flow	28
SyncPort® Connection	7	P/MV Operation	18	Unscheduled Flow	28
SD Card Reader	7	Flow Sensors	18	Alarm Delay	28
Battery	7	Solar Sync® Sensor	19	Alarm Clear Delay	28
Earth-Ground Lug	7	Clik Sensors	20	Flow Monitor Setup	28
Transformer Assembly	7	Selectable Sensor	20	Flow Zones	29
Wiring Compartment Cover	7	Sensor Response	20	Station Setup	31
MCC Power Module	8	Flow Menu	21	Learn Flow	31
Flow Sensor Inputs	9	Clearing Flow Alarms	21	Hydraulic Summary	32
Wire Ties	9	Settings Menu	21	Flow Alarm Handling	32
Transformer Fuse	9	Time/Date	21	Flow Manager Setup	33
SmartPort® Connection	9	Regional Settings	21	Conditional Response	35
Programming and Operation	9	User Management	21	Decoders Menu	37
Attention Messages	10	Networking	22	Programming Decoders	38
Startup Screen	10	Controller Verification	22	Decoder Diagnostics	38
Viewing Messages	10	Diagnostics Menu	23	General Troubleshooting	39
Clearing Messages	10	View Logs	23		
Viewing Logs	10	Alarm Logs	23		
Home and Activity Screens	11	Controller Logs	23		
Activity Screen	11	Station Logs	23		
Names	12	Filter Logs	23		
Time/Date Settings	12	Export Logs	23		
Manual Operations	13	Module Info	24		
Manual Stations	13	Clik Sensor Diagnostics	24		
Manual Programs	13	Station P/MV Diagnostics	24		
Test Program	13	Flow Sensor Diagnostics	24		
Stop Commands	13	Solar Sync Sensor Diagnostics	24		
Stop All Irrigation	14	Decoder Diagnostics	24		
System Off	14	Wireless Valve Link Diagnostics	25		
Pause	14	Advanced Features	25		
Timed Off	14	Export Logs	25		
Selective Stop	14	Easy Retrieve® Memory	26		
Programs Menu	15	Reset Memory	26		
Intelligent Current Sensing	15	Firmware Update	27		
SmartStack	15	Conditional Response	27		

Module Compatibility

The MCC takes advantage of Hunter’s edge in modular design and shares many module options with other Hunter control products. ICM-800, ICM-2200, and EZ-DM Decoder Output Modules have been enhanced for the MCC and are backward-compatible with ICC2 Controllers. The MCC also uses the same communication modules as the ACC2 Controller, which may only require minor firmware updates after installation. Before installing any module in the MCC, be sure to review this compatibility table.

Station Expansion

After adding or changing any station output modules, be sure to press the Reset button in the centre back of the facepack.

Module	Description	Compatibility Notes
ICM-400	4-station output module	Not compatible with MCC
ICM-800	8-station output module	Compatible date code MAR 26 or later. Air vents included in cover of updated models.
ICM-2200	22-station output module	Compatible date code MAR 26 or later. Air vents included in cover of updated models.
EZ-DM	54-station EZ Decoder Output Module <i>Note: Two modules enable 108 stations</i>	Compatible date code MAR 26 or later. Older modules will not fit into MCC slots.
WVOM	Wireless Valve Output Module	Compatible with MCC
A2C-LTEM	Cellular communication module	Compatible with MCC
A2C-WIFI	Wi-Fi communication module	Compatible with MCC
A2C-LAN	Ethernet communication module	Compatible with MCC

Key Connections

(Back of Facepack)

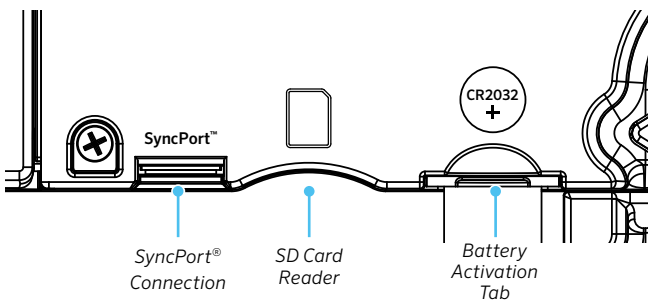

Controller Components

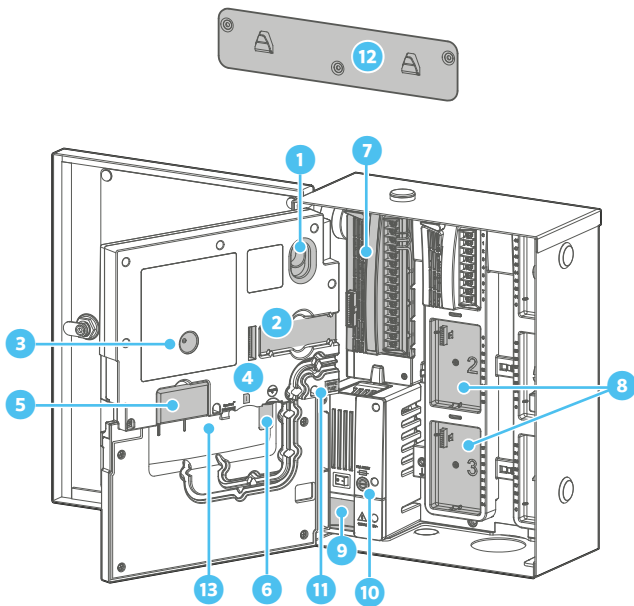

1. Door Latch
2. Ribbon Cable
3. Reset Button
4. SD Card Reader
5. Communication Module Slot
6. Battery Tab
7. Power Module (MCC-PM)
8. Output Module Slots
9. Transformer Wiring Compartment
10. Fuse
11. Spare Fuses
12. Wall Mount Bracket
13. SyncPort® Adapter

Facepack

The facepack is the main control panel used for configuring, programming, and operating the controller.

Removing the Front Door

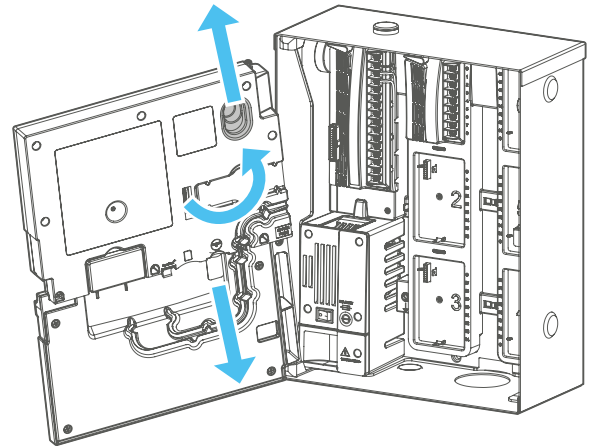

1. Disconnect the ribbon cable.
2. Pull the door latch down and tilt the door out.
3. Reverse the process after installation is complete, and reattach the ribbon cable.
4. Pull the battery tab to activate date/time backup.

Connecting and Disconnecting the Facepack

The facepack ribbon cable connection is located on the back of the control panel door. Turn off the power to the controller before connecting or disconnecting the facepack.

Door Latch

The quick-release door latch ensures easy installation and removal of the plastic facepack frame.

Wall Mount Bracket

The MCC comes with a unique wall mount for easy installation. Simply secure the wall mount to the mounting surface, then hang the controller on the steel hooks. When you open the controller enclosure, one additional mounting screw secures the controller in place.

A wall-mount template is supplied to guide the predrilling of holes.

Wall Mounting

1. Choose a location for the outdoor controller. Avoid direct sprinkler spray and high-voltage electrical devices. Shaded locations are recommended.

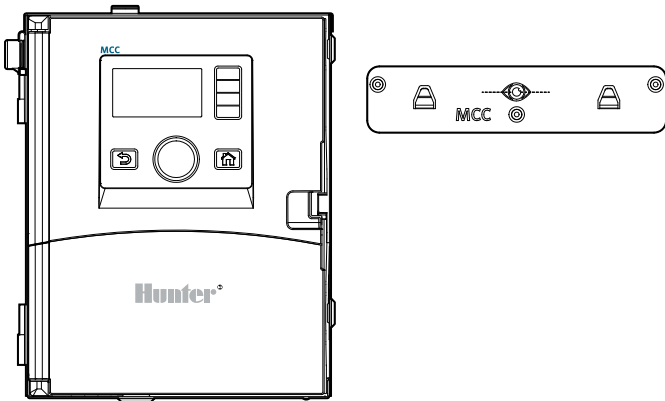

2. Locate the wall bracket and paper template.

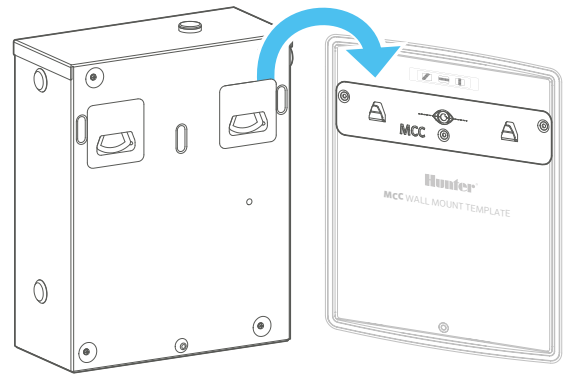

3. Tape the template in place, drill mounting holes, and install anchors.
4. Mount the wall bracket with the supplied hardware so the bottom sits at eye level with the display.

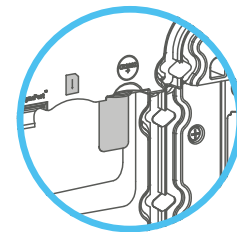
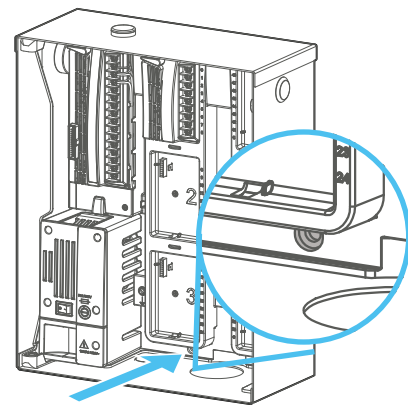

5. Hang the controller on the wall bracket hooks.
6. Open the door and install the bottom centre screw into the wall.
7. Remove the tab on the internal battery to enable date/time backup during power outages.
8. Proceed with connecting power.

SyncPort® Connection

The Hunter SyncPort Adapter is a proprietary connection for external Hunter interface devices. It is not used for Ethernet connections, although the connectors are similar.

SD Card Reader

The controller's facepack includes a built-in SD card reader with a preinstalled SD card. The SD card can update controller firmware and store logs, Easy Retrieve® Memory backups, and other information for use on another device. See the Advanced Features menu.

To update firmware in the field, scan the QR code located on the inside of the control panel or visit the MCC Controller product page at hunterirrigation.com/en-metric/irrigation-product/controllers/mcc.

Battery

Pull the tab to activate the battery for initial installation. The replaceable internal lithium battery backs up date and time settings during power outages (program settings and other data are non-volatile and do not require battery backup). The battery may last the life of the controller but can be easily replaced if necessary.

Use a standard CR2032 battery if replacement is needed. Take care to place the + side of the battery correctly.



NOTE: If the power to the controller is left off for extended periods, the battery will be consumed more quickly.

Earth-Ground Lug

A heavy-duty earth-ground lug is provided for lightning and surge protection. It should always be connected with heavy copper wire (minimum 12 AWG; 4 mm²) to approved grounding hardware buried in the earth at least 8.0' (2.5 m) from the controller, and as far away as possible from any wire paths.

Generally, earth-ground hardware consists of either an 8.0' (2.5 m) copper-clad steel rod driven all the way into earth, an 8.2' x 4.0" (2.5 m x 100 mm) wide copper plate (or both), or comparable earth-grounding hardware as approved by local code.

Do not connect the primary AC power earth-ground wire to this lug. The controller provides a safety ground connection inside the transformer wiring compartment.

Transformer Assembly

The transformer assembly provides the power supply for the entire controller. The transformer has a wiring compartment for primary connections to incoming power (120 VAC in the U.S.; 230 VAC in international regions). The transformer steps down to 24 VAC on the secondary side for power and control of the low-voltage controller components (facepack, station outputs, etc.).

Wiring Compartment Cover

This plastic junction box cover is where primary transformer connections are made. One captive #2 Phillips screw keeps the cover secure and easily accessible for service and maintenance.

MCC Power Module

The MCC Power Module, located in the upper left corner of the cabinet, is a vital component that includes connections for external sensors, pump/master valve outputs, common wire connections, and more. The Power Module can be easily replaced, if necessary, with the same type of locking lever as the output modules.

Power Module Wiring



hunter.help/MCCPowerModuleem

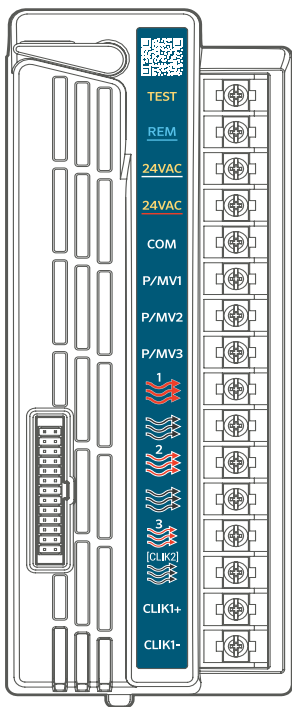

Terminal	Description	Notes
TEST	Constant 24 VAC for wire testing or other low-power needs	750 mA max
REM	Wiring terminal for SmartPort® Wiring Harness	Blue wire, data only
24VAC (white)	Terminal for SmartPort Wiring Harness or other low-power needs	750 mA max
24VAC (red)	Terminal for SmartPort Wiring Harness or other low-power needs	750 mA max
COM	Common terminal for P/MV power	P/MVs only
P/MV1	Pump/Master Valve output 1	800 mA max
P/MV2	Pump/Master Valve output 2	800 mA max
P/MV3	Pump/Master Valve output 3	800 mA max
Flow 1+	Flow Sensor 1 positive	
Flow 1-	Flow Sensor 1 negative	
Flow 2+	Flow Sensor 2 positive	
Flow 2-	Flow Sensor 2 negative	
*Selectable +	Selectable Sensor positive (Flow 3, Klik 2, or Solar Sync)	
*Selectable -	Selectable sensor negative (Flow 3, Klik 2, or Solar Sync)	
CLIK1+	Klik 1 positive	
CLIK1-	Klik 1 negative	

*Use as Flow 3, Klik 2, or Solar Sync. Selectable sensor can be configured in the Devices menu.

Flow Sensor Inputs

Flow sensor connections have DC voltage and polarity. When connecting a DC flow metre, verify that the positive lead from the sensor is connected to the red terminal and the negative sensor is connected to the black terminal.

There are two flow sensor inputs on the Power Supply Board. A third flow sensor can be added with the Selectable Sensor.

Wire Ties

Wire tie holders are moulded into the backplane near the output module slots to secure field wiring with plastic zip ties. This provides strain relief to keep field wires from pulling downward on the modules and keeps the inside neat and organised.

Additional wire tie holders are provided near the Power Module for sensor and other connections.

Transformer Fuse

The transformer uses a replaceable 0.2" x 0.8" (5 mm x 20 mm) electrical fuse, located next to the convenient on/off switch. Two spare fuses are stored in the bottom rear of the facepack frame, under the sticker labeled "Spare Fuse."

Replacement fuses comprise a standard glass body 0.2" x 0.8" (5 mm x 20 mm) 250 V, 2 A fast blow. They are available from Hunter (P/N 960300SP) in 10 packs, online, or from electronic appliance retailers and hardware stores.

SmartPort® Connection

The Hunter SmartPort Wiring Harness, located at the top left exterior corner (or inside plastic pedestals), has been a standard for decades and is designed to support remote control with Hunter's proprietary handheld ROAM or ROAM LR Remotes. It's also compatible with existing legacy Hunter remotes, such as the ROAM XL and ICR. See the specific remote control product manual for installation and operating tips.

Programming and Operation

The controller has a simple control panel with unique operating features.

1. The dial is used to rotate through menus. Push to select or enter information.
2. To the right of the LCD display are four soft keys. Their functions will change with each menu selection, as shown in the controller display.
3. The BACK button always returns you to the previous level before the current menu selection.
4. The HOME button always returns you to the Home screen view.

The Home screen shows the controller's status, including any currently running field devices. From here, the bottom soft key (titled Main Menu) directs you to all programming and setup functions, even when irrigation is active.

From the Main Menu button, you may enter the setup menus for all controller functions.

Once you've entered a programming screen, use the dial to navigate through all the fields of information. Press to select a specific field, rotate the dial to see the choices within that field or enter numbers or letters as applicable, and press to select.

Press Home at any time to return to the top level or navigate to other functions.

Attention Messages

A controller installation will trigger at least one Attention message due to loss of power during shipping and may be discovering new modules. This is normal.

Startup Screen

When power is first turned on, the Hunter logo screen will appear, and the controller will begin searching for any irrigation events missed when disconnected from power.

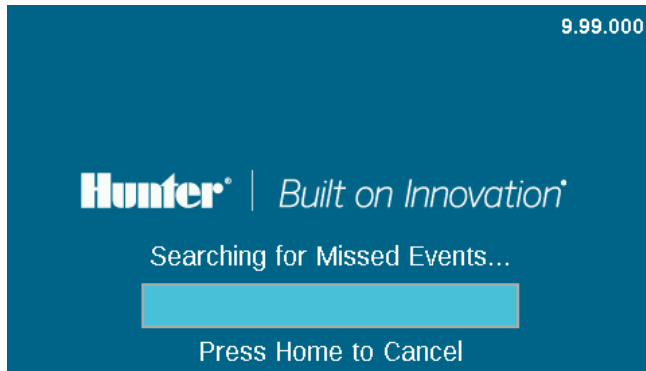

If installing or servicing the controller, this search can be cancelled by pressing the Home button on the facepack.

If the controller finishes searching for missed events (which takes about 1 minute), it will resume irrigating at the current time of day.

In automatic operations, the controller will always perform the search after any power outage. Watering that was missed during the outage will be recorded in the logs, then resume based on the time of the power restoration.

Viewing Messages

Messages on the screen do not interfere with normal irrigation.

A flashing alarm symbol at the bottom of the display indicates that unusual activity has been detected. When the symbol is flashing, a soft key labeled View Messages will appear.

- Press the Message key to view the most recent notifications in the Attention screen.
- From the Attention screen, you can View Logs to get more details about the messages and/or Clear Messages to return to the Home screen.

Clearing Messages

Attention messages in the display can be cleared by pressing the Clear Messages soft key after pressing View Messages. The message will still be available in the controller's logs.

Attention messages do not prevent watering or normal operation. However, they may announce a condition that can prevent or affect watering.

Viewing Logs

Press View Logs for more detailed information about each message.

The soft keys will link to the Alarm, Controller, and Station logs when an Attention message is displayed. The Filter Logs function lets you search for logs on a specific date or record number. You can also access logs at any time from the Diagnostics menu.

Home and Activity Screens

The Home screen offers basic information and soft-key shortcuts to common functions.

The current date and time are displayed in the bottom-left border. Date and time can be edited from the Settings menu.

If a Solar Sync Sensor is installed and enabled (Devices menu), the Solar Sync symbol will display the current adjustment percentage in the lower-right corner of the border.

If the red-and-white triangle symbol flashes in the lower-right corner, the controller has detected unusual activity. A soft key will change to View Messages to provide more information about the condition. The Messages screen permits clearing the message or accessing a direct shortcut to the View Logs function for more details. Messages on the screen do not interfere with normal irrigation.





If sensors are active (alarmed), the message will appear in red text in the upper-right corner.



Activity Screen

When the controller is running stations, the Home screen becomes the Activity screen, providing additional information and functions.

All active stations will display, along with the program running them, their current mode and the remaining run time.

System: RUNNING				 Stop  Manual  View Flow  Main Menu
Station	Pgm	Mode	Remaining	
1	1	Auto	00:02:48	
13	2	Auto	00:04:51	
21	3	Auto	00:04:54	

08:00:15
Saturday, 3/1/2026



NOTE: Individual items may be selected directly from the Activity screen and stopped without affecting other irrigation. For more information, see the [Selective Stop section on page 14](#).

The soft keys normally show Stop, Manual, View Flow (shows current flow, if a flow sensor is installed and enabled), and Main Menu.

Names

The controller lets you name items via an on-screen keyboard in the Name field or central control software, if connected. Names are useful in large systems, especially in the more advanced Flow Operations.

Select the Name field for any of these components, and a keyboard will appear so you can enter an alphanumeric name.

Enter Program Name

Sunny Turf

1 2 3 4 5 6 7 8 9 0

A B C D E F G H I J

K L M N O P Q R S T

U V W X Y Z Backspace

Done Space Copy Paste

Caps Lock

#+=

Symbols

Cursor Left

Cursor Right

You may also enter names via the Centralus™ Irrigation Management Platform and other central control options, if the controller is so equipped.

Items that can be named are:

- Programs
- Stations
- Blocks
- Clik Sensors
- Flow Zones
- MainSafe Zones

Time/Date Settings

From the Home screen, press Main Menu, then turn the dial to Settings.

Select Settings and rotate the dial to Regional Settings.

Choose language, time and date formats, and units of measurement. Press Back or Home to exit.

From the Settings menu, choose Time/Date: Set the current time and date, as well as Daylight Savings options. Press Back or Home to exit.

Time/Date

Current Time 13:47 Day of Week Sat

Current Date 3 Jan 2026

Daylight Saving Time

Automatically Adjust for DST

DST Switch Time 2:00

DST Begins On 2nd Sun of March

DST Ends On 1st Sun of November

Manual Operations



NOTE: For initial installation, you may need to configure master valves or other devices before manual testing. These settings are found under the [Devices Menu section on page 18](#).

On the Home screen, the Manual soft key lets you start stations, programs, or a test program. Once you press Manual, select from one of the following three choices.

Manual Stations

Run Manual Stations

Manual Run Type
 Sequential Simultaneous

Manual Run Events

Run Type	Number	Run Time	
		HH:MM	:SS
Station	1	00:05	:00
Station	2	00:05	:00
Station	3	00:05	:00

▶ Start

🗑 Delete

➕ Insert Line

✎ Fill Down

Specify one or more stations to run, and enter a run time for each. You can also run them simultaneously rather than sequentially by checking the Simultaneous box. Press the Start key to create a list.

Manual Programs

Run Manual Program

Program 1

Name

Select Step: 1

Run Type	Number	Runtime
Station	1	00:03:00
Station	2	00:03:00
Station	3	00:03:00
Station	4	00:03:00

➤ Next Program

▶ Start

⬆ Scroll Up

⬇ Scroll Down

To begin, select a program number, then the Start key. It's also possible to scroll down to a program event and start it from that point forward.

A Manual Station or Program Start will pause automatic watering until the Manual Program completes.

Test Program

The Test Program will run all stations in the controller for the run time entered on the screen. It's also possible to specify a station number and run all remaining stations from that number to the highest numbered station.

In the MCC Controller, the Test Program will only run stations that already have a run time in other programs.

Stop Commands

Any running irrigation can be stopped immediately from the Home screen. The top soft key offers the following choices for stopping irrigation.

Stop All Irrigation

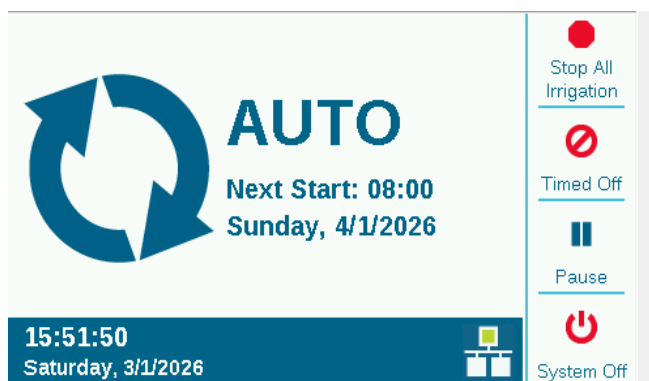

This immediately stops everything that is watering or running. The controller is still in Automatic irrigation mode and will resume watering at the next start time.

System Off

This turns off all irrigation and places the controller in permanent Off mode. No automatic irrigation will occur.

Pause

This interrupts all current activity until either Resume is pressed or 30 minutes have passed. Anything running will resume where it left off and continue for its remaining time. When items are paused, the Resume button will appear.

Timed Off

Like System Off, this stops all stations and prevents automatic irrigation, but only for a specified period of days. When the days have counted down to zero, the controller will resume automatic operations.

Selective Stop

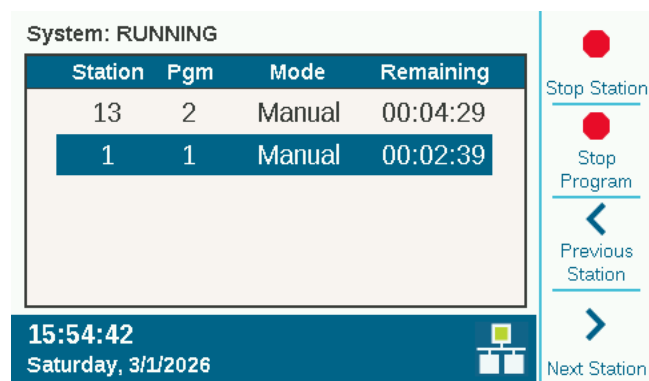

To stop a station or program, turn the dial to the Activity screen and scroll through the list of running stations and programs. Click to highlight the desired selection. You'll then have two choices:

- **Stop Station** halts only the highlighted station and lets other active stations continue running.
- **Stop Program** discontinues the entire program that started the chosen station. Other programs that are running will continue.

Programs Menu

To create a watering schedule, visit the Main Menu and dial to the Programs menu. This is where basic automatic irrigation is set up.

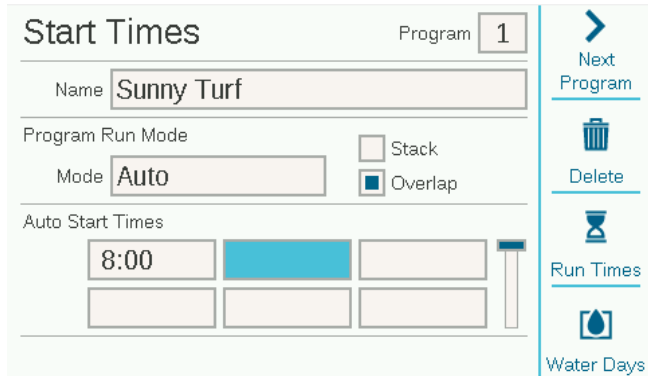

A basic program requires Start Times, Run Times, and Water Days to operate automatically. There are 16 possible automatic irrigation programs, each with up to 10 Start Times.



NOTE: Each program has a limit of 64 events.

Start Times: Verify that you have the correct program number, or select and enter the program you want.

Name (optional): You may enter a name for the program, if you wish.

Run Mode: This mode must be set to Auto to run automatically.

Manual Only: This does not water automatically but stores station run times for manual irrigation only. These programs do not have day schedules or start times. They may be changed to Auto mode at any time if automatic operation is desired.

Start to End: This feature allows the controller to repeat continuously from a start time to an end time. It is useful for germination and plant establishment purposes.

Stack or Overlap: Stack means the program must run by itself, while Overlap allows it to run at the same time as other programs. If a program is stacked, its actual start time may change if other programs overlap it.

Auto Start Times: Enter the time the program starts. The faster you rotate the dial, the faster the times will change. Each program may have up to 10 start times.

Intelligent Current Sensing

The controller has no artificial programming limits that prevent program and station overlap. It senses how much electrical current is being drawn and automatically suspends stations if the combined current threatens the transformer.

It's also possible to set Controller and Station Limits (Stations > Station Limits) to control how many outputs may operate at once.

The MCC Controller may run as many as eight Hunter stations (plus up to three P/MV outputs) simultaneously before suspending additional stations. Environmental factors or higher-draw solenoids may cause overcurrent protection to activate at lower station counts.

To view the current draw of each decoder output module, visit the Decoder Diagnostics screen.

SmartStack

It's possible to set a limit on the total number of programs that can run simultaneously. This setting is found on the Stations > Station Limits screen.

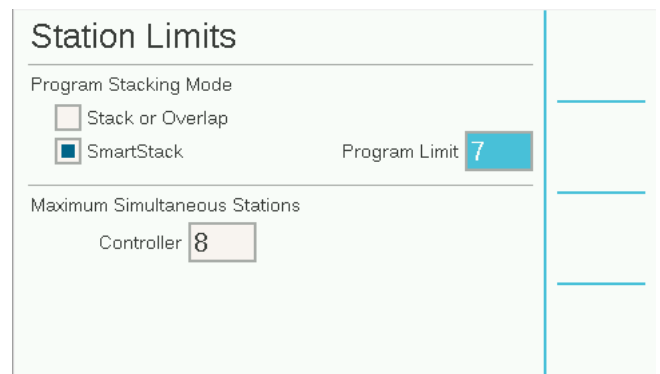

Enter the maximum number of programs that are allowed to coexist. If more programs have start times that overlap with these programs, they will be forced to wait until one of the original programs ends.

Stations Menu

Many of the items in Stations are covered in more detail in other sections.

The screenshot shows the 'Station Setup' interface for 'Station 1'. It includes a 'Name' field with 'Station 1', 'Station P/MV Usage' with checkboxes for 1, 2, and 3 (checkbox 1 is checked), 'Flow Zone' set to 1, 'Flow Priority' checkbox, 'Flow Measurement Settings' with 'Flow Rate' at 18 GPM and 'Copy Flow' checkbox, and 'Delay' set to 1:00 (M:SS). On the right side, there are navigation buttons: 'Next Station', 'Station Diagnostics', 'Copy', and 'Paste'.

Station Setup

The Station Setup menu allows you to name your stations. Most other functions are described in more detail in the [Flow Operations section on page 27](#).

Station P/MV Usage: Indicates which normally closed P/MV outputs the station will activate when it runs

Flow Zone: Used for station flow zone assignment (required for Flow Manager and/or Flow Monitor)

Flow Priority: Check this box to prioritize a station's watering time in flow management

Flow Rate: Enter or learn the typical flow for the station (used in Flow Manager and Flow Monitor)

Delay: Set the amount of time a station can run before high or low flows cause an alarm; set longer delays for stations that take longer to stabilize flow

Unavailable P/MVs: PM/V boxes marked with an "X" are unavailable because they are already assigned to other Flow Zones or MainSafe zones.

Cycle & Soak

This function is used to control runoff and puddles when soil or slope cannot absorb all irrigation at once.

Set the Cycle to the maximum time the station can run at once before runoff occurs.

Set the Soak to the minimum time the station must wait before applying another cycle. The controller will water other stations during the Soak period. For this reason, Cycle & Soak generally does not extend the overall watering time significantly.

The copy and paste shortcuts allow quick duplication of these settings to stations with similar characteristics.

Blocks

A Block is an electronic group of stations that runs at the same time, for the same run time, within a program.

To create a Block, dial to the Stations menu and select Blocks. Enter a Name for the Block if you wish.

The screenshot shows the 'Blocks' interface for 'Block 1'. It includes a 'Name' field with 'Block 1', 'Stations' section with input boxes for 11, 23, and 29, and 'Cycle & Soak' section with 'Block Cycle Time' at 0:15 (H:MM) and 'Block Soak Time' at 0:30 (H:MM). On the right side, there are navigation buttons: 'Next Block', 'Delete', 'Copy', and 'Paste'.

Dial to the station spaces, then click and enter the station numbers that will be in the Block.

Blocks may also have their own Cycle & Soak settings.

Blocks may have up to 4 stations each.

There can be up to 64 Blocks per controller.

They can be mixed in a program with individual stations.



NOTE: Programs with Blocks are not limited in any way by other programs that are running. The controller will not turn on more stations than it can handle, so there are no artificial rules governing the Blocks.

Station Limits

Station Limits control how many stations and programs can run at the same time.

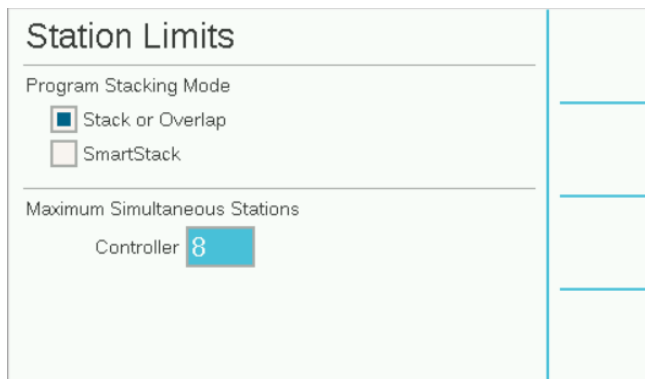

Station Limits

Program Stacking Mode

Stack or Overlap

SmartStack

Maximum Simultaneous Stations

Controller **8**

Program Stacking Mode

- **Stack or Overlap:** Each program can be set to either overlap with other programs or run alone (stack). Programs set to stack will not run at the same time as other programs.
- **SmartStack:** Sets a maximum number of programs that may overlap across the entire controller.

Maximum Simultaneous Stations

This feature sets the total number of stations that can run at one time for any reason across the entire controller. It's mainly used with Flow Manager but applies to all irrigation activity.

If Flow Manager is enabled, the display also shows Program Limits. This sets the maximum number of stations that may run within a single program. It can be used to distribute irrigation across more programs when Flow Manager is scheduling stations to meet a flow-rate target.

The MCC Controller supports up to eight simultaneous stations per controller and up to three Master Valves.

Station Summary

The Station Summary is a report available for each station showing exactly how it's going to run, based on the current setup and programming. It's a report only and does not allow changes to be made directly from this screen.

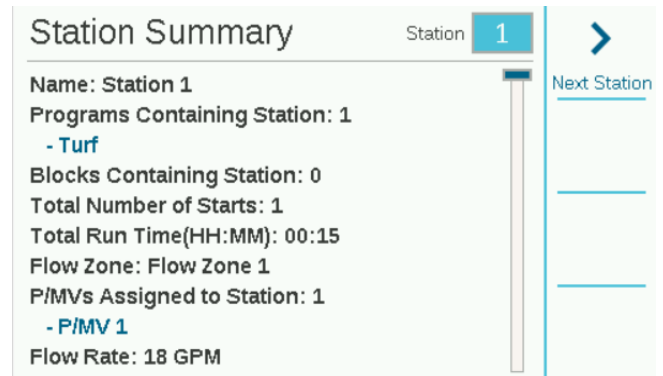

Station Summary Station **1** [Next Station](#)

Name: Station 1

Programs Containing Station: 1
- Turf

Blocks Containing Station: 0

Total Number of Starts: 1

Total Run Time(HH:MM): 00:15

Flow Zone: Flow Zone 1

P/MVs Assigned to Station: 1
- P/MV 1

Flow Rate: 18 GPM

Devices Menu

This is one of the most important screens in setup. Here, we teach the controller which devices are connected. Some of these functions are covered in greater detail in their specific sections.

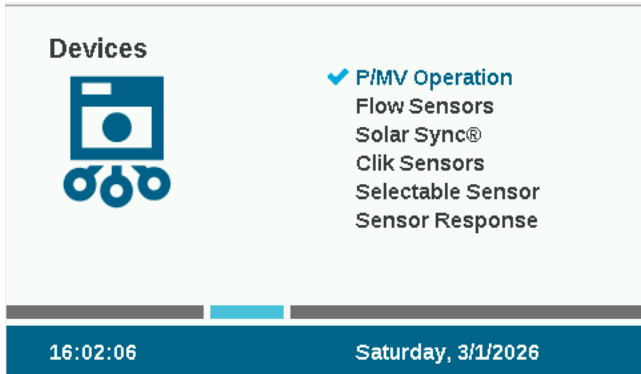

P/MV Operation

Select the P/MV you'd like to configure.

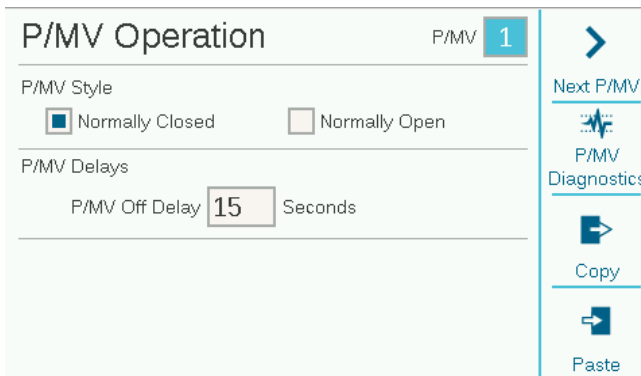

Normally Closed: Each P/MV will be checked for normally closed operation. This is a station-level setting, meaning the P/MV is activated by stations when they start running. The Station Setup menu allows you to set each station for the P/MV outputs it needs to run water.

Normally Open: This option, discussed further in the [Flow Operations section on page 27](#), is not a station-level setting. In this mode, the valve remains open during normal operation. If the controller detects a problem at the Flow Zone or MainSafe level, it will activate the normally open P/MV to shut off the water.

P/MV Off Delay: This sets how long the P/MV output remains active after a station stops calling for it, such as during Delay Between Stations. It's preset to 15 seconds but can be changed. Use caution, as Hunter is not responsible for damage to pump components when longer delays are set.

P/MV Diagnostics: Press the soft key for P/MV Diagnostics to view the status and current draw of each active P/MV output. Inactive P/MVs are not shown.

Set the Style — P/MV or Normally Open — for the pump/master valve outputs.

Pump starts should always be set to Normally Closed to prevent damage.

The P/MV Delay sets how long the P/MV will remain active if a station pauses, such as during the Delay Between Stations.

Flow Sensors

To connect one or more flow sensors, set up operation in the Devices > Flow Sensors menu.

Select the sensor input number (1-3) to configure. The controller includes two Flow Sensors, and a third may be added with the Selectable Sensor option.

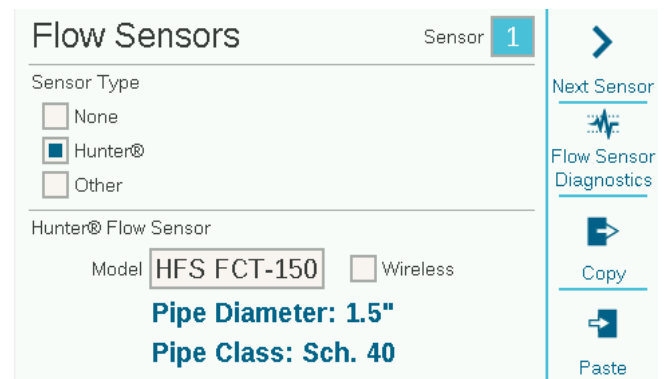

For each flow sensor, check the box for either “Hunter” or “Other” flow metres.

If **Hunter** is checked, move to the Model field and select the Hunter FCT model number for the diameter of the pipe. This is all that is necessary to calibrate the setup.

“Wireless” is only checked for use with the Hunter Wireless Flow Sensor (WFS), which requires a receiver installed at the controller.

If **Other** is checked, you must select the Flow Sensor Style and enter the calibration information. Some use K-factor and Offset, and others are Pulse type. Consult the flow metre supplier’s documentation for the correct settings or contact Hunter Technical Support for additional information.

K-Factor and Offset: Obtain these values from the flow sensor manual and enter.

Pulse type: Set the value equal to a single pulse. Amounts higher than 0.01 GPM or l/min are not recommended.

Flow Sensors

Sensor 1

Sensor Type

None

Hunter®

Other

Flow Sensor Style

K-Factor & Offset

Pulse

1 Pulse = 0000 .0100

Gal

Ltr

Next Sensor

Flow Sensor Diagnostics

Copy

Paste

Enter the information for each flow sensor that is connected to a flow terminal. There are copy and paste soft keys available, if all the metres are the same type and size.

Once you enter the information for each flow sensor input, the controller is ready to read flow. However, each flow sensor must be attached to a Flow Zone (Flow > Flow Zones) before real-time monitoring can occur.

Flow Totals may be viewed at the Flow menu.

Current flow rates (by sensor) can be read from the Home/Activity screen with the View Flow soft key.

Flow Monitoring: Additional setup for station level flow monitoring is required in the Flow > Flow Zones menu and in the Stations > Station Setup menu.

Solar Sync® Sensor

Solar Sync can only be connected to the MCC Selectable Sensor. Choose the Solar Sync option on the Selectable Sensor screen, then set up operation in the Devices > Solar Sync menu.

Solar Sync®

Enable Solar Sync®

Solar Sync® Settings

Region 3 Adjust = 100%*

+/- Water Adjustment 5

Solar Sync® Delay

Delay 12 Days

Adjustment During Delay 90%

Solar Sync® Diagnostics

Check the box to Enable Solar Sync.

Choose the Region and set the Water Adjustment, according to the Solar Sync manual instructions.

For normal operations, this is all that's necessary. It will take the Solar Sync two or three days to register enough climate data to begin adjusting.

Solar Sync Delay allows a number of days to wait before automatic Solar Sync adjustment goes into effect (to establish new landscape, for example). Enter a number of days (1-250) to wait, and specify the **Adjustment During Delay** percentage to use during the delay period. At the end of the delay, the Solar Sync will begin adjusting automatically for the current climate conditions.

The delay does not interfere with the Solar Sync Rain and Temperature functions. They will be operational during the delay.

Complete the setup by scheduling the programs to use Solar Sync in the Program > Seasonal Adjust menu.

Clik Sensors

Dial to the Devices menu, and select Clik Sensors for basic Hunter Clik Sensors.

To set up a sensor, click the box for Enable Clik Sensor Input.

Clik Sensors Sensor 1

Name Clik Sensor 1

Enable Clik Sensor Input

Sensor Style

Normally Open

Normally Closed

Next Sensor

Clik Sensor Diagnostics

There's only one standard Clik sensor input on the Power Module, but the Selectable Sensor may be used to add a second.

Controller sensor inputs are factory set to Normally Closed but can be changed to Normally Open for other contact-closure sensors.

It's also possible to enter a name for individual sensors.

Selectable Sensor

The MCC Controller features a single selectable sensor input terminal on the power module. This can be used for any one of the three following choices:

- **Solar Sync Sensor:** Adds a Solar Sync data input for automatic climate adjustment
- **Flow Sensor 3:** Adds a third flow sensor input to the two that are labeled on the power module
- **Clik Sensor 2:** Adds a second Clik Sensor (contact-closure) input

Selectable Sensor

Selectable Sensor Input Configuration

Solar Sync®

Flow Sensor 3

Clik Sensor 2

Choose the type of sensor you want for this terminal.
You may then configure that sensor by pressing the shortcut key.

Setup Flow Sensors

Once you've made a selection, the setup for the 2 sensor will be available on the corresponding menu under Devices. A shortcut key will appear for the selected sensor type, taking you directly to the correct menu.

Sensor Response

Located in the Devices menu, Sensor Response determines which sensors will shut down specific programs during normal operation.

Responses are configured one program at a time. To apply the same settings to multiple programs, configure the first program and press the Copy soft key. Then select another program number and press Paste to duplicate the settings.

Sensor Response Program 1

Name Turf

Clik Sensor 1	Suspend
Clik Sensor 2	Ignore
Solar Sync® Rain	Suspend
Solar Sync® Freeze	Ignore

Next Program

Rain Delay

Copy

Paste

Ignore: This means the program does not respond to the sensor.

Suspend (recommended): This means the program suspends watering when sensor is active (alarmed) but keeps track of time. If the sensor returns to normal, the suspended program will resume irrigating where it should be at that time in the schedule. The program will end when it was originally scheduled to end.

Pause (use caution): When the sensor becomes active, the program stops at its current point. Once it returns to normal, the program resumes where it left off, which may cause it to finish later than originally scheduled.

A program cannot be set to both Pause and Suspend for different sensors, since these responses cannot operate at the same time. If changing the response for one sensor automatically changes another response for the same program, this is expected behaviour.

Rain Delay: In the Sensor Response menu, press the Rain Delay soft key. This optional setting keeps irrigation off for a selected number of days after the sensor returns to normal. Choose the number of days for each Clik sensor input.

Flow Menu

The Flow menu includes all setup options for the various flow functions. These are described in detail in the [Flow Operations section on page 27](#).

Clearing Flow Alarms

The Clear Flow Alarm function enables a Flow Zone that has an Overflow alarm to water again.

If the Alarm Clear Delay is set to Manual Only, you must manually clear the alarm with this function before watering can resume.

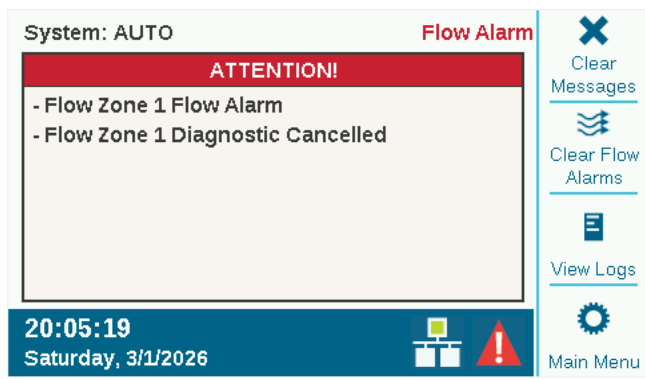

If Alarm Clear Delay is set to a time in HH:MM format, the controller can automatically run irrigation in the Flow Zone again after the time has elapsed.

If the controller is connected to Centralus or Hunter360™ Software, a Clear Flow Alarm command is available from the software.

Settings Menu

Time/Date

This function sets time and date. See the [Time/Date Settings section on page 12](#).

Regional Settings

This function sets regional preferences, including language and units of measure. See the [Time/Date Settings section on page 12](#).

User Management

This function lets you create a password for the controller. You'll be required to enter the correct personal identification number (PIN) before operating the controller. If a single PIN is entered at the top, it's required for all users and grants the same level of access to each.

Check the Enable User Management box to create one or more PINs. Once it's checked, only an Admin-level user who is successfully logged in can uncheck this box.

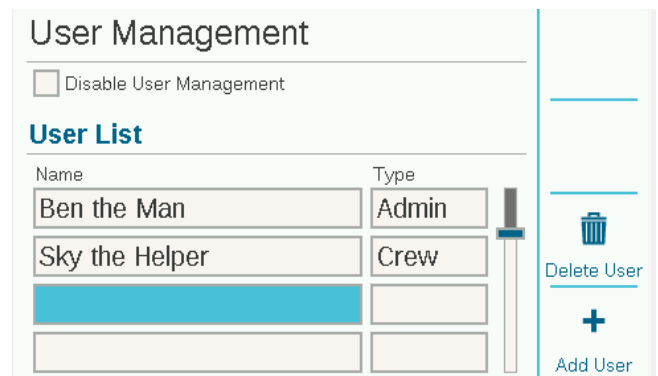

It's also possible to define different users and individual PINs.

There are two levels of authorization: **Admin** and **Crew**.

Admins can modify programming and all other settings.

Crew-level access allows manual operation only and the ability to view programming.

User logins are tracked in the Controller Log.

To add a user, press the New User soft key. You may then enter the user's name with the keyboard that appears when the Name field is selected. For each user, select the Type (Admin or Crew), and create a unique PIN for that person.

An Admin can delete users with the Delete User soft key.

Users will be automatically logged out after 30 minutes of inactivity.

Forgot PIN: If a customer forgets their PIN, please contact Hunter Technical Support for assistance.

Networking

If the internal Wi-Fi, LAN, or LTE connection module is installed, Networking displays the network settings for these devices. If none are installed, the Networking screen will show they're not available.

Network Info: Displays current communication information

Network Info

Cellular Connection Status: **Connected** -72dBm

Access Point Name: **zipitwireless.com.attz** Carrier Profile: **AT&T**

Cell Module Type: **LTE-M1**
Serial Number: **48a4 725b e92e 00b3**
IP Address: **192.168.0.28**
IMEI: **11-222222-333333-4**
ICCID: **1111 2222 3333 4444 5555**

Edit Carrier Profile
Edit APN

If the controller has a communication module installed, this screen displays the connection status and the controller's serial number.



NOTE: The MCC displays the 16-character serial number from the controller itself, not the communication module. The communication module serial number is not used in MCC connections.

The serial number is the most important detail for Hunter installation support. Taking a photo of this screen makes it easy to share with support personnel.

Central Control Setup: The controller can be connected via Wi-Fi, LAN, or Cellular to the Centralus™ Irrigation Management Platform from Hunter Industries. Centralus is a cloud-based, fully featured central control solution for the MCC Controller family and other Hunter controllers.

For specific connection information, consult the manual supplied with the communication module.

MCC cabinets have numerous knockouts and hole plugs to facilitate external antenna mounting and extension.

Controller Verification

Adding an MCC Controller to Centralus web-based central control requires a few steps.

You will need a free Hunter Centralus account to add a new controller.



hunter.help/centralussupport

1. From the controller's location, log in to your Centralus account, and choose Add Controller.
2. Select the type of controller and enter a name for it.
3. Choose the type of communications (if Cellular, you will be prompted to purchase a data plan before proceeding).
4. Enter the controller's serial number in the software, found on the controller's Networking screen (Settings menu). The software will say that it's sending a Verification Code to the controller.
5. Navigate to the Controller Verification screen in the Settings menu, and a short code will be displayed. Enter this code into Centralus to complete the setup process.

Settings

- Time/Date
- Regional Settings
- User Management
- Networking
- ✓ Controller Verification**

06:39:38PM Thursday, 2/12/2026

Diagnostics Menu

Attention messages do not interfere with normal automatic irrigation.

All Attention messages in the Home screen create logs. The first step to understanding any problem or message is to click the View Logs soft key or access the logs from the Diagnostics menu.

Other helpful tools are located within Diagnostics. Decoder controllers include separate diagnostics for decoder conditions in the Decoder menu.

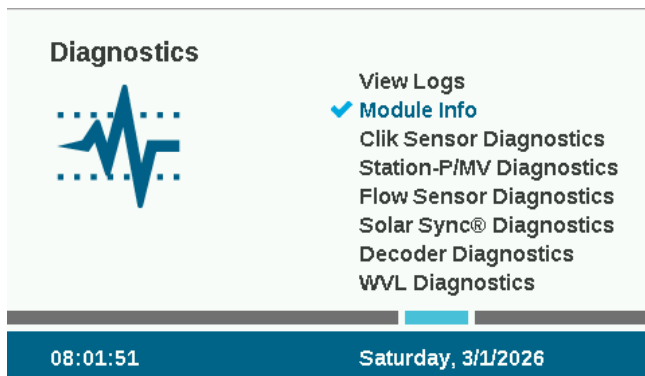

View Logs

There are three log types, along with a filter function to narrow the displayed logs.

Alarm Logs

The controller will store the last 250 alarm logs, with date and time, beginning with the most recent alarm. Rotate the dial to advance forward and backward through the alarm list.

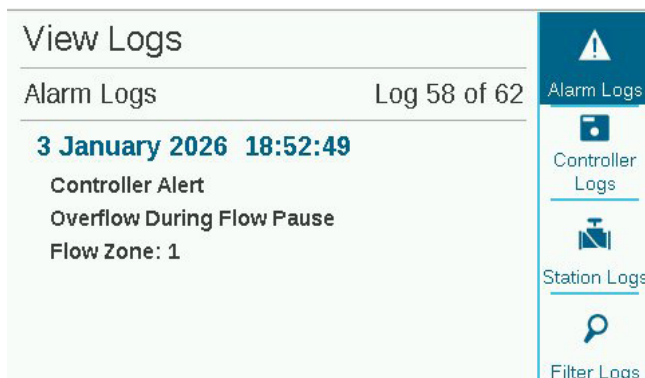

Controller Logs

Other significant messages that are not technically alarms are stored in the controller logs (up to 250 events). They are also arranged by date and time, with the most recent log first.

Station Logs

Station logs record every event that occurs in the controller (up to 1,500 events), beginning with the most recent. This can be useful for advanced troubleshooting or verification that a station actually watered.

Filter Logs

This allows any of the three logs to be filtered by date or record number.

Export Logs

All logs can be written to the SD card. This function is located and described in more detail in the [Advanced Features section on page 25](#).

Module Info

Select Module Info to view the current firmware version for all modules in the controller. Modules that are empty or not reporting are shown as Not Present.

Module Info	
Facepack	0.14.001 b
Station Modules:	
Slot 1: ICM-800	4.01.000 b
Slot 2: ICM-800	4.01.000 b
Slot 3: EZDM	5.01.000 b
Slot 4: WVOM	2.01.000 b
Slot 5/6: ICM-2200	4.01.000 b
Solar Sync®	Not Enabled
WiFi Module	4.16.001
Chipset	19.6.3

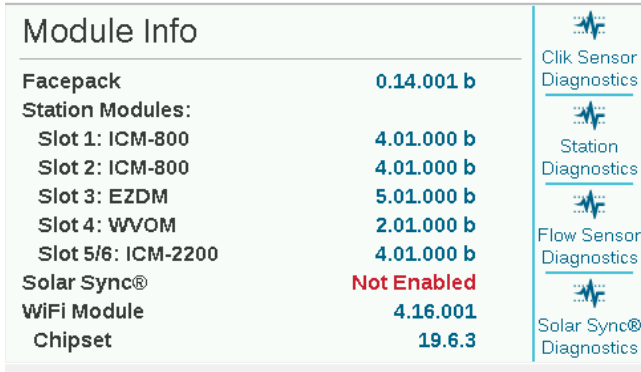

Soft keys allow shortcuts to other diagnostic checks, which are also available directly from the Diagnostics menu.

Clik Sensor Diagnostics

Sensor: This shows each sensor, its current state, and whether it's In Use (assigned to any programs).

State: This displays the sensor's current status. Inactive means the sensor is operating normally.

- **Active:** Sensor is currently alarmed.
- **Delayed:** Sensor was recently alarmed and is now inactive, but a Rain Delay is in effect for the sensor.
- **Disabled:** Sensor's check box is unchecked in the Devices menu and will not trigger any response.

In Use: This indicates whether the sensor is currently active in the Sensor Response menu and able to shut down programs.

Station P/MV Diagnostics

This shows the electrical current draw in milliamps for all active stations and P/MV outputs.

Flow Sensor Diagnostics

This displays the configuration of each flow sensor and the current flow. Frequency shows the sensor's click or pulse rate for diagnostic purposes.

Solar Sync Sensor Diagnostics

This shows the last time the Solar Sync Sensor communicated, as well as the current state of its alarm sensors (Rain and Freeze).

The Test Connection soft key checks for the presence of a wired sensor or a wireless sensor's receiver. Test Connection does not initiate communications to the wireless sensor itself because it's a one-way connection.

Decoder Diagnostics

This shortcut appears only if an EZ-DM Decoder Output Module is detected and takes you directly to the Decoder Diagnostics screen. See the [Decoder Diagnostics section on page 38](#) for more information.

Wireless Valve Link Diagnostics

If one or more Wireless Valve Output Modules (WVOM) are detected, the WVL Diagnostics selection will appear on the Diagnostics menu.

Serial Number	Stations P/MVs	Signal Strength	Battery Status	Repeater
00011F40	P/MV1,1,2,3	90%	5%	
0001A800	9,10,11,12	80%	5%	
00018100	P/MV2,25,26,33	89%	5%	

This screen cannot be used to program WVL devices and is not a substitute for the Hunter WVL App. However, it provides a convenient look at the status of wireless valve connections directly on the controller display.

The WVL Diagnostics soft key will show the configuration for WVLs in the field.

If more than one WVOM is installed, the screen allows you to select which module you want to review.



NOTE: If multiple WVOMs are installed, they must operate on different radio channels. These can be assigned only through the Hunter WVL App.

At the selected WVOM, the screen displays the serial number of each WVL assigned to it. The Station/P/MV column lists station numbers or P/MVs assigned to each WVL (be sure to avoid duplicate addresses). The following columns show signal strength, battery status, and whether that device is using a repeater for communication.

This screen displays information from the station's last activation and updates automatically every 24 hours.

Advanced Features

Advanced Features

- Export Logs
- Easy Retrieve
- Reset Memory
- Firmware Update
- Conditional Response

08:09:37 Saturday, 3/1/2026

Export Logs

Logs may be exported in a simple text format to the internal SD card in the facepack for troubleshooting or record-keeping.

1. Enter a unique file name by clicking in the File Name box.
2. Select the boxes for the types of Logs desired.
3. Select the Export Logs button, then click it to save the file to the SD card. The card may then be inserted into a computer or other device with an SD card reader and the contents saved or sent to another location.

Easy Retrieve® Memory

This feature saves the current controller setup so it can be restored to this point at a later date.

Easy Retrieve

Controller Memory

Save Restore

SD Card File

Enter File Name

111.MCC

Save Restore

Controller Memory: Only one setup can be saved, and it will remain unless you make changes and create a new Easy Retrieve backup in the future. You can choose Restore at any time, which will revert the controller back to the setup saved in the most recent Easy Retrieve backup.

SD Card File: You can also save Easy Retrieve backups to the SD card via the SD card slot in the facepack. To do so, an SD card must be installed. You may also restore from the SD card to any saved Easy Retrieve backup in the future.

When saving to the SD card, you must enter a name for the file. Click to select the File Name, and a keyboard will appear. Enter the name for the file and choose Done from the keyboard when complete.

Using the SD card and different file names lets you save as many backups as the card can hold, each with a different name. You can restore any one of them from the SD card by entering the correct file name. The SD card cannot display a list of the saved files, so be sure to enter the file name exactly as it is on the card.

Reset Memory

Sometimes it's preferable to simply erase the controller and start over. There are several Reset options.

Reset Memory

Individual Reset

All Programming and Devices

Flow Totals

Delete

All Programming and Devices: This erases all programs and device setups but keeps the Flow Totals intact.

It will require complete reprogramming of all devices, flow setups, and irrigation schedules.

Flow Totals: This clears the flow total history and resets all to zero.

Check the boxes for the items you wish to clear and press Delete. The controller will ask for confirmation before erasing any data.

Firmware Update

The controller can be updated whenever a new version of the operating system or any internal module is released. These updates are usually available from hunterirrigation.com/en-metric/support/mcc-firmware-updates or sent by email. Staying current with controller updates is strongly recommended.

1. Copy the update files onto a compatible SD card and insert it into the SD card reader.
2. Select Firmware Updates from the Settings menu. The controller will detect and display available updates on the card.

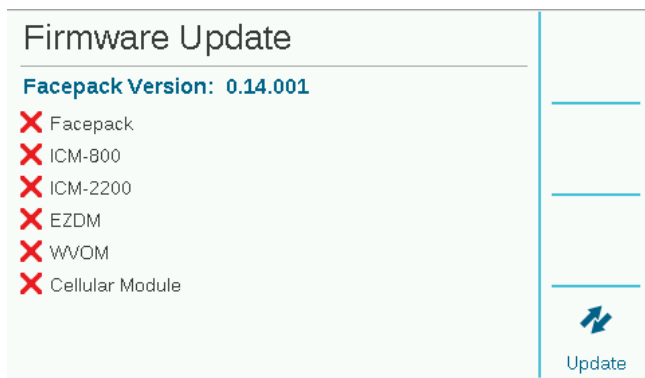

Press the Update soft key to copy the files to the controller. Wait until the automatic reboot is complete, and the controller will be up to date.

It's also possible to update connected controller facepacks and communication modules over the air (OTA) via Centralus central control.



NOTE: Do not turn off power to the controller or facepack once the update has started. This may result in damage.

Conditional Response

Conditional Response enables active responses to various sensors or other conditions. It can be used to:

1. Start a station, block, or program based on sensor input
2. Switch P/MV outputs based on switch position
3. Activate an external device (such as an SOS light) to indicate a controller alarm

This is a very powerful option and should be used with care. Read the [Conditional Response section on page 35](#) before using these features.

Flow Operations

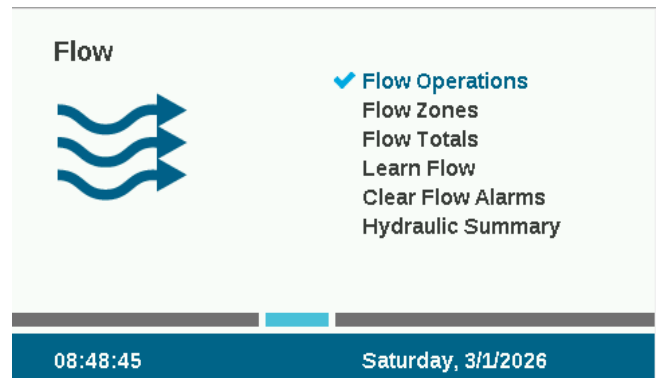

Flow Operations has two key components: the Flow Manager and the Flow Monitor. There is also an optional MainSafe® function for higher-level protection of the water source/mainline. This can be enabled separately if required.

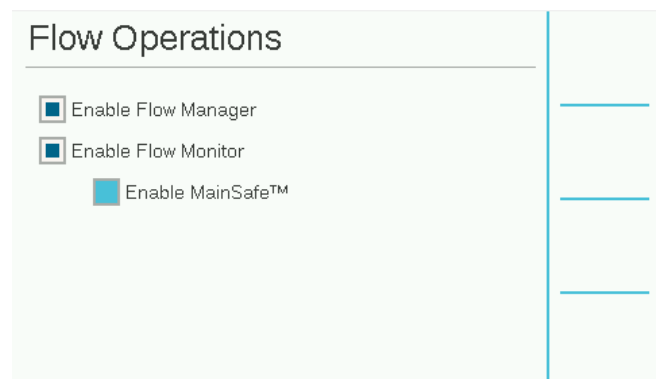

Checking the box to enable any of these functions displays a reminder of the steps required to configure them. Press the Continue soft key to set up the selected function.

Flow Manager

Flow Manager uses station flow information to run multiple stations simultaneously to achieve the user-specified flow rate target. It will turn on as many stations as it can to stay at or near the flow target until there are no more stations to run. This does not require a flow sensor input.

Flow Monitor

Flow Monitor verifies that the actual flow matches the learned flow for all running stations. It also performs diagnostics or shutdowns when alarms occur. Flow Monitor requires one or more flow sensor inputs to operate and at least one master valve (P/MV) per flow sensor to be effective.

From the Flow menu, check the boxes to Enable Flow Manager and/or Enable Flow Monitor if desired. Proceed to the various setup options described under each section.

MainSafe® System Protection

MainSafe Technology provides an optional level of flow monitoring and protection above the Flow Zone level. It's especially useful when:

- More than one Flow Zone has been configured from the same water supply
- There's a long distance between the point of connection and the beginning of the actual Flow Zone(s)
- Separate mainlines are in a constantly charged state for the sole purpose of manual watering

MainSafe zones generally require their own flow sensor and master valve. Often these are normally open master valves, which only close during alarm events.

To set up MainSafe protection, dial to the Flow menu and select MainSafes.

MainSafe Setup Screen

1. Press the Setup soft key. This lets you name the MainSafe area (recommended).
2. Check the box to enable Monitor Flow.
3. Assign the P/MV output and flow sensor assigned to the MainSafe area.

The Flow Zones' checks and Xs cannot be set here. They show the relationship of this MainSafe to the Flow Zones. These are assigned in the Flow Zones menu (Flow Map screen).

Flow Limits Screen

Press the Flow Limits soft key.

Maximum Flow

Maximum Flow is an absolute high limit for all flow from the MainSafe level (the water source). If the flow rate exceeds that amount, irrigation will shut down. It does not matter what stations are running or what the learned flow is.

This should be considerably larger than the maximum flow allowed in normal irrigation in all downstream Flow Zones (so that it does not alarm before station-level and Flow Zone diagnostics can be performed).

Unscheduled Flow

Unscheduled Flow is any flow detected by the flow sensor when no stations are running. You may enter a flow rate to permit manual watering up to the specified amount, without triggering an alarm or shutting off the water. If unscheduled flow above that amount is detected, an alarm will occur.

Alarm Delay

High flows will trigger an alarm immediately if this is set to None. Otherwise, the controller waits until the high flow has lasted for the time specified. When set in MM:SS format, the longest delay is 9 minutes, 59 seconds. This eliminates false alarms caused by temporary flow surges.

Alarm Clear Delay

This sets the amount of time a MainSafe zone will remain shut down before allowing new automatic irrigation attempts. When set in HH:MM format, the longest delay setting is 23 hours, 59 minutes.

If Alarm Clear Delay is set to Manual Only, automatic irrigation will not resume after a high-flow or unscheduled flow alarm until it's manually cleared by an operator at the controller. The operator must dial to the Flow menu, select Clear Flow Alarms, choose the Flow Alarms that should be cleared, and click Clear Selected.

Flow Monitor Setup

The Flow Monitor requires the following steps to operate correctly:

1. Install and set up one or more flow sensors (Devices menu).
2. Install and set up one or more P/MVs (Devices menu).
3. Set up Flow Zones and complete all information for the Flow Zone (Flow menu).
4. Associate each station with a Flow Zone (Station Setup menu).
5. Learn Flow for all stations with run times (Flow menu).

Flow Zones

Flow Zones Flow Zone 1

Name

Manage Flow

Flow Target

Monitor Flow

Overflow Alarm Limit

Underflow Alarm Limit

Next Flow Zone

Flow Map

Allowances

Flow Limits

A Flow Zone defines a section of pipe and a group of stations attached to that pipe, which are managed as a hydraulic unit. Flow Zones are used for both Flow Manager and Flow Monitor.

MCC Controllers have three Flow Zones available. Most Flow Zones will have a master valve and often a flow sensor. If you need a third flow sensor, you can add one with the Selectable Sensor setting on the Devices menu if that input has not been assigned to another function.



NOTE: MainSafe is a kind of Flow Zone and, if enabled, will count as one of the three Flow Zones available.

Each Flow Zone has a check box for Manage Flow and Monitor Flow. To monitor flow, check that box. Then complete the settings and rules for the Flow Zone.

MainSafe zones are only used for flow monitoring purposes and do not have a box for flow management.

Overflow/Underflow Alarm Limits: The controller sets the overflow and underflow limits for each station's learned flow at the flow zone level. Enter the maximum and minimum flow percentages the Flow Zone should allow for the stations attached to it. If these limits are set too close to 100%, there is a greater risk of false alarms due to natural flow fluctuations.

Flow Map

In the Flow Zones menu, press the Flow Map soft key.

Flow Zones Flow Zone 1

Name

Flow Sensor Assignment

1 2 3

P/MV Assignment

1 2 3

Next Flow Zone

Allowances

Setup

Flow Limits

This tells the controller how the Flow Zone is connected and indicates which devices are used in that hydraulic unit. All stations must be downstream from the flow sensors and master valves checked here.

Flow Sensor Assignment: Check the box for the Flow Sensor or sensors connected to the Flow Zone.

If an X appears in a Flow Sensor box, the sensor is already assigned elsewhere and can't be used for this Flow Zone.

If a Flow Sensor number does not appear, it has already been assigned to another.

P/MV Assignment: Check the box for the master valve installed in line with this Flow Zone's flow sensor.

If an X appears in a P/MV box, it's already assigned to another Flow Zone or MainSafe and is not available here.

If a P/MV number does not appear, it's already assigned elsewhere and is not available for monitoring in the selected Flow Zone.

Flow Limits

In the Flow Zones menu, press the Flow Limits soft key.

The screenshot shows the 'Flow Zones' menu for 'Flow Zone 1'. The 'Name' field is 'Flow Zone 1'. Under 'Flow Zone Flow Limits', 'Maximum Flow' is set to 'None' and 'Unscheduled Flow' is set to 'Off'. Under 'Flow Alarm Delays', 'Alarm Delay' is set to '2:00 (M:SS)' and 'Alarm Clear Delay' is set to '23:59 (HH:MM)'. On the right side, there are soft keys: 'Next Flow Zone', 'Flow Map', 'Allowances', and 'Setup'.

Maximum Flow: This defines the highest flow rate the Flow Zone will ever allow under any condition. This should be considerably larger than the maximum flow allowed in normal irrigation so that it doesn't alarm before station-level diagnostics can be performed. When the flow sensor detects a flow higher than this, the irrigation will be shut down.

Unscheduled Flow: This is the maximum flow allowed when no stations are running. It permits manual hand-watering when the controller is not irrigating automatically. If flow exceeds this limit, the controller will alarm.

If Unscheduled Flow is set to OFF, the controller will not respond to unscheduled flow.

Flow Alarm Delays: This sets the time before the Max or Unscheduled Flow rates trigger an alarm, and the time the Flow Zone will remain shut down.

Alarm Delay: High flows will trigger an alarm immediately if this is set to None. Otherwise, the controller waits until the high flow has lasted for the time specified. When set in MM:SS format, the longest delay is 9 minutes, 59 seconds. This eliminates false alarms caused by temporary flow surges.

This delay should be longer than the delays for the stations attached to the Flow Zone.

Alarm Clear Delay: This sets the time a Flow Zone remains shut down before allowing new automatic irrigation attempts. When set in HH:MM format, the longest delay setting is 23 hours, 59 minutes.

If Alarm Clear Delay is set to Manual Only, automatic irrigation will not resume after a high-flow or unscheduled flow alarm until it's manually cleared by an operator at the controller. The operator must dial to the Flow menu, select Clear Flow Alarms, select the Flow Alarms that should be cleared, and click Clear Selected.

Flow Allowances

In the Flow Zones menu, press the Allowances soft key.

The screenshot shows the 'Flow Zones' menu for 'Flow Zone 1'. The 'Name' field is 'Flow Zone 1'. Under 'Watering Budget', 'Monthly Budget' is set to '850000 GAL'. Under 'Manual Watering Allowance', 'Additional Flow' is set to 'None'. On the right side, there are soft keys: 'Next Flow Zone', 'Flow Map', 'Setup', and 'Flow Limits'.

Watering Budget: Enter the total flow allowed in this Flow Zone for the calendar month. If the total flow exceeds the monthly budget, an alarm message will appear on the screen. The controller will not automatically stop watering when this alarm occurs.

Manual Watering Allowance: This defines extra flow capacity for manual irrigation. The controller adds this value to all other limits, so alarms won't occur until the expected flow plus this allowance is exceeded.

Station Setup

Dial to the Stations menu and choose Station Setup. Each station must be assigned to a Flow Zone to complete Flow Monitor operation.

The screenshot shows the 'Station Setup' interface for Station 1. The 'Name' field is 'Station 1'. Under 'Station P/MV Usage', checkboxes for 1, 2, and 3 are present. 'Flow Zone' is set to 1, and 'Flow Priority' is unchecked. 'Flow Measurement Settings' shows 'Flow Rate' as 11 GPM and 'Copy Flow' as unchecked. 'Delay' is set to 0:15 (M:SS). On the right, there are buttons for 'Next Station', 'Station Diagnostics', 'Copy', and 'Paste'.

Station P/MV Usage: Station P/MV usage may have already been assigned during basic operations setup. If not, the desired P/MV activations may be made here for each station. If some selections are grey and not selectable, the P/MV output has already been assigned to a different function.

Flow Zone: This critical setting tells the controller which Flow Zone the station belongs to. In effect, it also indicates which flow sensor will measure the flow for the station. Flow monitoring cannot work until all necessary stations have been assigned to a Flow Zone.

Flow Priority: The priority setting is used for Flow Manager, but not for Flow Monitor. It helps the controller decide which stations to run sooner to achieve flow targets.

Flow Measurement Settings: These settings define the expected flow for each station during normal operation. The controller can learn these values automatically with a flow sensor, or you can enter them manually.

For Flow Monitor, this should be left blank until the Flow Learning function fills it in automatically.

For Flow Manager, learned flow is the most accurate. However, it's also possible to enter the flow rate by hand if the controller is not equipped with flow sensing.

Copy and Paste: The Copy and Paste soft keys can be used to duplicate the upper half of the Station Setup screen for multiple similar stations on the same Flow Zone. They will copy the P/MV Usage and Flow Zone settings to subsequent stations.

Set up the first station, press the Copy button, click the Next Station soft key, and Paste. It's easiest to work down one Flow Zone at a time if multiple Flow Zones are created.

Learn Flow

The final step in Flow Monitor setup is the actual learning process.

Dial to the Flow menu and select Learn Flow. The screen will display the status of the last Learn Flow attempt, if any.

The screenshot shows the 'Learn Flow' screen. It features a 'Learn Flow Summary' table with the following data:

Metric	Value
Flow Sensors Configured:	1
Stations with Run Times:	30
Stations with Flow Rates:	9
Stations Failed to Learn:	1

On the right side, there are four navigation buttons: 'Summary', 'Have Flow', 'Failed', and 'Learn'.

Flow learning will only test stations that already have a run time in a program.

Flow learning will cancel all other irrigation, automatic and manual, until the learning is complete. Flow cannot be learned while other stations are running for other reasons.

Press the **Report** soft key to verify that stations are ready to learn. The report shows how many flow sensors are configured, how many stations have run times, and how many already have flow rate data.

If all stations have run times, press the **Learn** soft key. The controller will start stations one at a time for up to 5 minutes each (plus the station's delay time) to learn the flow. If flow stabilizes sooner, the controller will move to the next station without running the full 5 minutes.

Flow learning can be a lengthy process, depending on the number of stations and the stability of the flow.

When the learning is complete, the **Learn Flow** screen will summarize how many stations were learned and how many failed. Troubleshoot the failed stations (either in setup or in the field) and try learning again to fill in the failed stations.

Schedule Flow Learning: It's possible to set the controller to Learn Flow automatically at a later time and date. Remember that **flow learning will cancel any other automatic irrigation**, so choose a time and date that won't conflict with critical irrigation.

Hydraulic Summary

Dial to the Flow menu and select Hydraulic Summary.

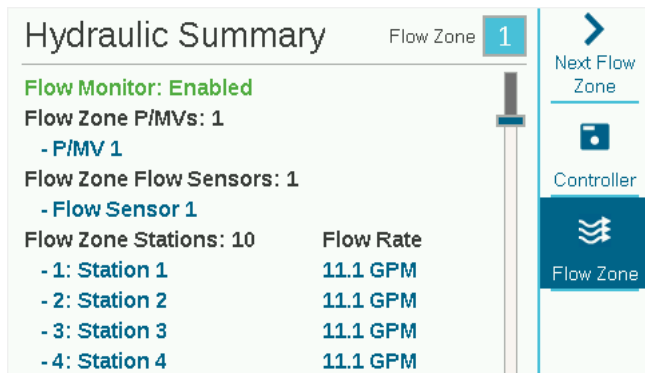

The Hydraulic Summary reports exactly how the controller hydraulics are set up at the moment. It shows the connections of all flow-related objects, from Flow Zones, Flow Sensors, and P/MVs to individual stations.

Use the soft keys to view by Controller or by Flow Zone.

This is the easiest way to review the current setup and confirm if anything is incorrect or incomplete.

View Flow: The current flow rate on all sensors can be viewed from the Home/Activity screen at any time. Press the View Flow soft key to see the actual flow up to six flow sensors.

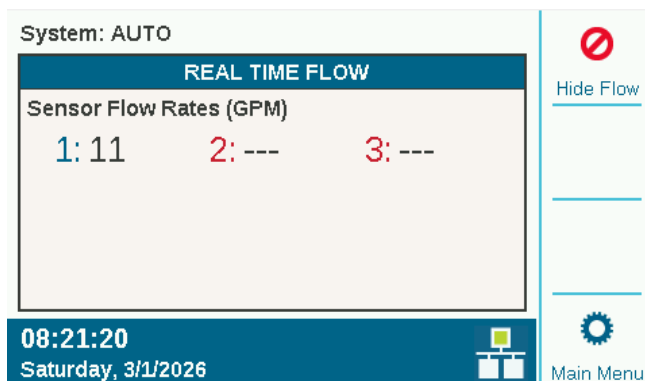

If the controller is equipped with the optional Wi-Fi module, the current flow can also be viewed on a mobile device.

Flow Alarm Handling

When stations are running, the Flow Monitor continuously checks the actual flow from the sensor(s) against the combined learned flow of the stations, including the overflow and underflow percentages allowed in the Flow Zone. It also checks this flow against the higher-level Flow Zone limits.

If the total amount of running stations exceeds the permissible station delay period, the controller pauses all stations (shutting off the P/MV) in the Flow Zone. It waits 60 seconds after the stations are paused for the flow to drop to near zero.

Station-Level Alarms

If the flow drops to near zero when the Flow Zone is paused, the controller then begins running the stations that were running at the time of the alarm, one by one, to determine which station(s) are causing the high-flow conditions. The controller will mark failed stations in the logs and continue irrigating with stations that pass the individual flow tests.

Flow Zone Alarms

If flow does not drop substantially during the diagnostic pause period, the controller determines there is a Mainline Overflow and will not resume irrigating or perform further diagnostics. It will remain shut down for the period specified in the Alarm Clear Delay setting on the Flow Zones screen.



When flow alarms occur at the Flow Zone or MainSafe level, you can clear them from Flow > Clear Flow Alarms. A shortcut soft key to Clear Flow Alarms will also appear after you select View Messages.

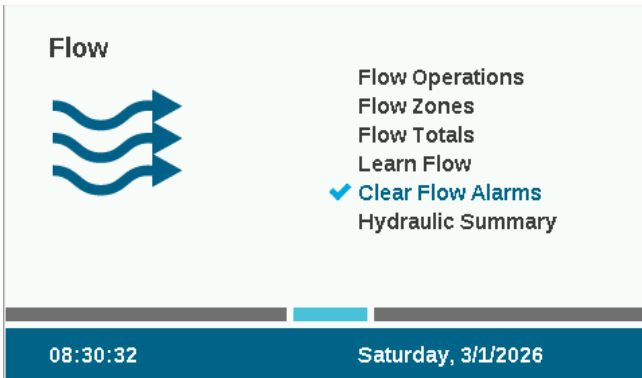

If the actual flow exceeds the Maximum Flow allowance for the Flow Zone and continues for the time set in the Alarm Delay, the Flow Zone alarms and shuts down without further diagnostics. The controller assumes the overflow condition is due to a mainline break above the station level.

If flow exceeds any Unscheduled Flow allowance when no stations should be running, and it continues for the time set in the Alarm Delay, the controller will shut down the Flow Zone.

Flow Manager Setup

Flow Manager runs multiple stations at the same time to reach a programmable flow target. This allows the controller to choose which stations run together, keep total flow near the pipe’s design capacity, and reduce total watering time.

Flow Manager does not require a flow sensor, but it must have station flow values to work with. If a sensor is not available for flow learning, approximate values may be entered manually.

Flow Manager also requires one or more Flow Zones, and stations must be assigned to those zones. Flow Manager and Flow Monitor can operate simultaneously, using the same flow information in different ways.

Flow Manager requires the following steps to operate correctly:

1. Set up Flow Zones and set Flow Targets (Flow > Flow Zones).
2. Attach stations to Flow Zones (Stations > Station Setup).
3. Learn or enter station flow rates (Stations > Station Setup).
4. Set Controller Program Limits (Stations > Station Limits), if desired.

Flow Zones

Dial to the Flow menu and select Flow Zones if they have not already been created. The Flow Zone defines a section of pipe and a group of stations attached to that pipe, which are managed as a hydraulic unit.

For Flow Manager, it’s only necessary to Enable Flow Management and set the Flow Target. Check the box for Manage Flow.

Flow Target

The Flow Target box sets the desired flow rate for the Flow Zone throughout irrigation when flow management is enabled. Enter the desired rate of flow that is best for the mainline pipe diameter (recommended at 5.0' (1.5 m) per second) or a preference based on other factors.

This is the only setting necessary at the Flow Zone menu for the Flow Manager function. Flow Manager will try to run enough simultaneous stations to stay at or near this flow rate whenever programs are available to run. It may select eligible stations to run in any order to remain close to the flow target.

Station Setup

Flow Manager requires:

- The station's Flow Zone assignment
- The Flow priority (checked or not checked)
- The station's Flow Rate

Flow Zone

This specifies the Flow Zone assigned to the station.

If multiple Flow Zones exist (groups of stations sharing the same mainline), each zone may use a different Flow Target.

Flow Zones can operate without Flow Manager, even while others are managed.

Flow Priority

The Priority setting helps the controller decide which stations to run sooner to achieve flow targets. Stations with the Priority box checked are given preference, allowing less critical stations to start later.

Flow Rate

If the system has a flow sensor, it's best to use the Learn Flow function so the controller can set these values automatically.

If the system does not have a flow sensor, look up or calculate reasonable flow values for each station, then enter them manually.

Note that the Copy and Paste function does not work with flow rates. It copies only the upper half of the screen, including P/MV and Flow Zone assignments.

Station Limits

Go to Stations > Station Limits to review or change the number of stations allowed to run simultaneously.

Adjusting Station Limits isn't required for Flow Manager to operate, but it can help tailor overall flow performance.

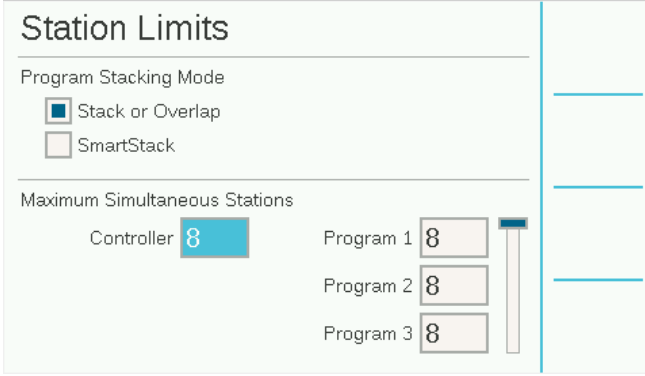

Maximum Simultaneous Stations sets a hard limit on the number of stations the controller can run simultaneously, regardless of Flow Manager or other settings. The MCC Controller can run approximately eight conventionally wired Hunter solenoids at once, including P/MV outputs. If Wireless Valve Link outputs are available, this number may be much higher since they don't draw current from the transformer.

These limits may vary based on system conditions, and you may have other reasons to restrict the number of stations running simultaneously.

Enter a Controller value that meets your needs if the default of eight isn't appropriate.

If Flow Manager is enabled, you can also enter a maximum number of simultaneous stations per program. This can help distribute irrigation across multiple programs when desired.

Example: Program 1 runs turf zones, and Program 2 runs shrub zones. If they're both part of the same flow-managed Flow Zone and you know the Flow Zone can run about six zones at once, you could set a limit of three on Program 1 and three on Program 2. The controller will still manage flow based on your target, but could only run three in either program to get there.

If the Flow Target rates are well below the Controller and Program station limits, those limits will never be reached. The controller will decide which stations to run and in what order.

Conditional Response

Conditional Responses allow a sensor or condition to trigger an action. This can be as simple as telling a station to start when a sensor is opened to much more complex operations, such as switching water supplies to a Flow Zone based on sensor position.

Conditional Responses are written in the form of statements following this structure: "If this happens, then do that."

The controller may have up to 35 Conditional Response statements. Some responses may require more than one statement to achieve certain results, such as switching P/MVs.

Setting Up a Conditional Response

Go to Advanced Settings and select Conditional Response. Each response has a soft key for the "If" condition, the "Then" condition (or action), and "Review Statement" to verify that the complete response will meet the goal.



NOTE: You must review the statement and check Enable for the response to take effect.

Available responses depend on the object (Type) chosen in the "If" statement.

The "If" statement defines the condition that triggers the response.

The "Then" statement defines the action taken.

Clik Sensors can use alarms as a trigger, or they can initiate actions based solely on their position (Closed or Open) without generating an alarm.

Examples: A Clik Sensor can start a program or station when it alarms, or it can switch between two master valves based on whether it's open or closed.

Flow Zones and MainSafe zones can use Max Flow rate or Unscheduled Flow conditions as triggers. Flow Zone triggers can activate an external alarm indicator or close a P/MV.

You can also use "Any Alarm" or a list of "Critical Alarms" as triggers, usually to activate an external alarm indicator. See the [SOS Station Output section on page 36](#) for more information.

You must Review and check Enable before the Conditional Response statement becomes active.

Conditional Response Types

The following table shows Conditional Response options for various situations.

"If" Type	Selection	Condition (Trigger)	"Then" Actions	Other Rules
Clik Sensors	Clik 1	Alarm	Start Station	Manual/Auto Stop if Clears Yes/No
	Clik 2	Open	Start Block	
	Clik 3	Close	Start Program Close P/MV Start SOS	
Solar Sync	Solar Sync Rain Solar Sync Freeze	Alarm		
Flow Zone	Flow Zone 1-6	Max Flow, Unscheduled Flow Mainline Overflow	Start SOS	
Water Source	Water Source 1-6	Max Flow	Start SOS	
Any Alarm	All Alarms	Unscheduled Flow	Close P/MV	
Critical Alarm	Serious Alarms	Alarm	Start SOS	

SOS Station Output

The SOS output is an external trigger that activates a dedicated warning light during critical alarms. This allows a standalone controller to alert maintenance staff about internal problems such as a flow alarm.

Hunter offers an accessory for the ACC2 Controller for this purpose, but it was not designed to fit in the more compact MCC Controller. However, the feature may still be used with an external light powered by a 24 VAC output from any unused conventional station output.

Starting Stations, Programs, and Blocks

When using Conditional Response to start a Station, Program, or Block, other options appear below the selection.

Mode

If Mode is set to Manual, the Station, Program, or Block will run by itself, and all other automatic irrigation pauses until the response is complete.

If Mode is set to Auto, the response runs without halting other scheduled irrigation. If Flow Manager is active, the response may not begin immediately. Its stations will be added to the Flow Target as capacity becomes available.

If Stop if Condition Clears is checked, the Station, Block, or Program runs only while the trigger condition remains active. If the condition persists, a Station or Block will run for its specified run time, and a Program will run once for its full duration.

If the box is not checked, the response continues for the total Run Time or for the entire Program, regardless of whether the condition clears.

Switching P/MVs

To enable P/MV switching on sensor input, each station in the affected Flow Zone should be set to call for both P/MV outputs.

When the sensor alarms or changes position, configure it to Close P/MV for the valve that should not be used. Because stations call for both P/MVs and the sensor disables one of them, only a single P/MV will ever be active at a time.

Example: A site has two water sources — potable and non-potable — each with its own master valve. A float switch monitors the non-potable reservoir. All stations are set in Station Setup to call for both master valves.

- When the float switch is closed, it disables the potable-water P/MV, so irrigation uses the non-potable water supply.
- When the float switch is open, it disables the non-potable P/MV, so irrigation uses the potable supply.

Since only one switch position is active at a time, no more than one P/MV can be disabled. This ensures that one water source remains available for irrigation.

Decoders Menu

MCC Controllers have an additional menu for decoder functions when one or more EZ-DM Decoder Output Modules are detected. The MCC is only designed to work with Hunter EZ Decoders and will not operate any other decoder types.

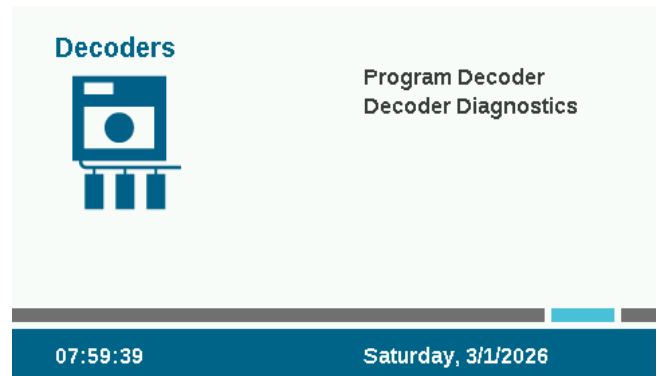

If an EZ-DM Decoder Output Module is installed, the controller will resize to at least 54 stations after you press the Reset button on the back of the facepack.

If there are two EZ-DMs installed, it will resize to a maximum of 108 stations after the Reset button is pushed.



NOTE: Programs with Blocks are not limited in any way by other programs that are running. The controller will not turn on more stations than it can handle, so there are no artificial rules governing the Blocks.

Programming Decoders

Hunter EZ Decoders have programmable station numbering that is entered directly into the decoder before installation.

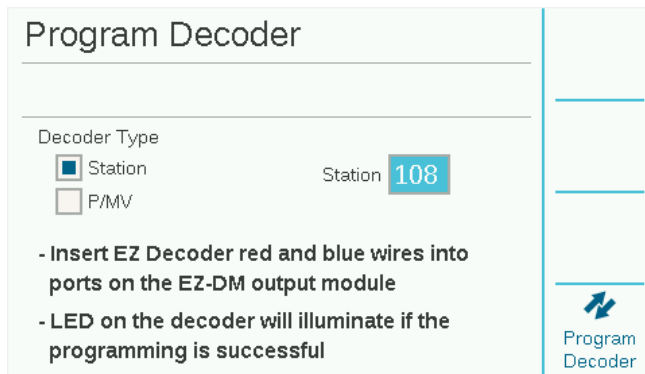

Select Program Decoder and follow the on-screen instructions. These remind you to insert the red and blue wires from the decoder into the programming port holes on the EZ-DM Module (it does not matter which colour goes where).

Select whether the decoder will be a station number (1 to 108) or a P/MV output (1 to 3). Do not create duplicate decoder addresses in the same controller, even when using two EZ-DM Modules, to avoid accidental overcurrent alarms.

Press the Program Decoder soft key and wait for the LED on the decoder to flash. This confirms it has accepted the programmed address.

Use a permanent marker to write the station or P/MV number on the decoder label to complete the process. Repeat the same steps if you wish to change a station or P/MV assignment that's already programmed in a decoder.

Decoder Diagnostics

The Diagnostics menu will show vital statistics for each EZ-DM Module installed, with multiple EZ-DMs on separate rows.

Module Number	Current	Module Status	Line Status
1	398mA	Active	Active
2	398mA	Active	Active

 **NOTE:** Each EZ-DM Module supports up to 54 EZ Decoders, with up to two two-wire paths.

The screen will show the module's controller slot, its milliamp current draw, its active status, and whether the two-wire path is receiving voltage.

Wire Test: A soft key allows you to start the Wire Test mode for field tracking purposes. This can be used to trace field wiring when decoders are all inactive or haven't been installed yet. It will energize the wire path with 24 VAC at 50/60 Hz, depending on local AC power frequency.

General Troubleshooting

Symptom	Solution
Attention messages	Press View Messages and/or View Logs Continue troubleshooting based on log reports
No Water Window violation	Review program Start Time and No Water Window setup
Won't run programs/stations	Review Program or Station Summary
No display	Make sure facepack cable is connected at both ends Make sure power to controller is on Check transformer fuse
Overflow messages	Verify that flow limits and delays allow for some variation Check system for leaks and malfunctions
Won't read flow	Check flow sensor wiring Check flow sensor setup, including Selectable Sensor Review Hydraulic Summary
Won't read Solar Sync	Verify sensor setup, including Selectable Sensor Verify Solar Sync is enabled (Programming menu) Verify sensor is communicating (Diagnostics menu) Verify Seasonal Adjust mode is set to Solar Sync (Programming > Seasonal Adjust)
Electrical or module malfunctions	Review all components (Diagnostics menu)

Compliance

FCC

This equipment has been tested and found to comply with the limits for a Class B digital device pursuant to Part 15 of the FCC Rules. These limits are designed to provide reasonable protection against harmful interference in a residential installation. This equipment generates, uses, and can radiate radio frequency energy and, if not installed and used in accordance with the instructions, may cause harmful interference to radio communications. However, there is no guarantee that interference will not occur in a particular installation. If this equipment does cause harmful interference to radio or television reception, which can be determined by turning the equipment off and on, you are encouraged to try to correct the interference by taking one or more of the following measures:

- Reorient or relocate the receiving antenna.
- Increase the separation between the equipment and receiver.
- Connect the equipment into an outlet on a circuit different from that of which the receiver is connected.
- Consult the dealer or an experienced radio/TV technician for help.

Changes or modifications not expressly approved by Hunter Industries could void the user's authority to operate this device. If necessary, consult a representative of Hunter Industries Inc. or an experienced radio/television technician for additional suggestions.

Notes





Helping our customers succeed is what drives us. While our passion for innovation and engineering is built into everything we do, it is our commitment to exceptional support that we hope will keep you in the Hunter family of customers for years to come.

A handwritten signature in black ink, appearing to read 'G. R. Hunter', with a long horizontal flourish extending to the right.

Gregory R. Hunter, CEO of Hunter Industries

A handwritten signature in black ink, appearing to read 'Denise S. Mullikin', written in a cursive style.

Denise Mullikin, President, Landscape Division